



Kidz A2

6

EnglishHouse

Contents

Introduction Kidz A2.....	3
Unit 1. Family members. Look and read	5
Unit 2. How does it make you feel?	24
Unit 3. Jobs for everyone	39
Unit 4. Camping	58
Unit 5. Holidays	72



EnglishHouse

Introduction

This booklet was made to be part of the resources used by Elementary school teachers in order to develop language skills.

The contents and activities in it include the vocabulary and structures of the Young Learners level for the Cambridge English Flyers exam, so that your students will gradually get familiar with it.

The EnglishHouse project also includes:

- Three practice exams to monitor and evaluate the students' performance at the Cambridge English Flyers level.
- Access to our website for further practice.

Learning English is fun!

To download the tracks for the listening activities, go to www.englishouse.mx



EnglishHouse

Family members.

Look and read. Then write names for the family members and answer the questions.



- 1 Who is married? _____
- 2 Who is single? _____
- 3 How many brothers has Kim got? _____
- 4 How many sisters has Kim got? _____
- 5 Who is Kim's cousin? _____
- 6 Who is Kim's aunt? _____



Months of the year

Look and unscramble.

- | | | | | | |
|---|----------|-------|----|-----------|-------|
| 1 | hMrac | | 7 | eJnu | |
| 2 | rtObcoe | | 8 | yJlu | |
| 3 | yaJnrau | | 9 | eNmrebov | |
| 4 | ayM | | 10 | rAlip | |
| 5 | eerDmbec | | 11 | treebSmpe | |
| 6 | uryFbear | | 12 | tAgsuu | |

Now write the months of the year in the correct order.

- | | | | |
|---------|----------|----------|----------|
| 1 _____ | 2 _____ | 3 _____ | 4 _____ |
| 5 _____ | 6 _____ | 7 _____ | 8 _____ |
| 9 _____ | 10 _____ | 11 _____ | 12 _____ |

Read and answer the questions. Then make the questions to a friend and write.

- How old are you?
- When is your birthday?
- Which is your favourite month?
- Why?
- How old are you?
- When is your birthday?
- Which is your favourite month?
- Why?



At home

Look at the furniture in the rooms and write three words in each section in the table below.

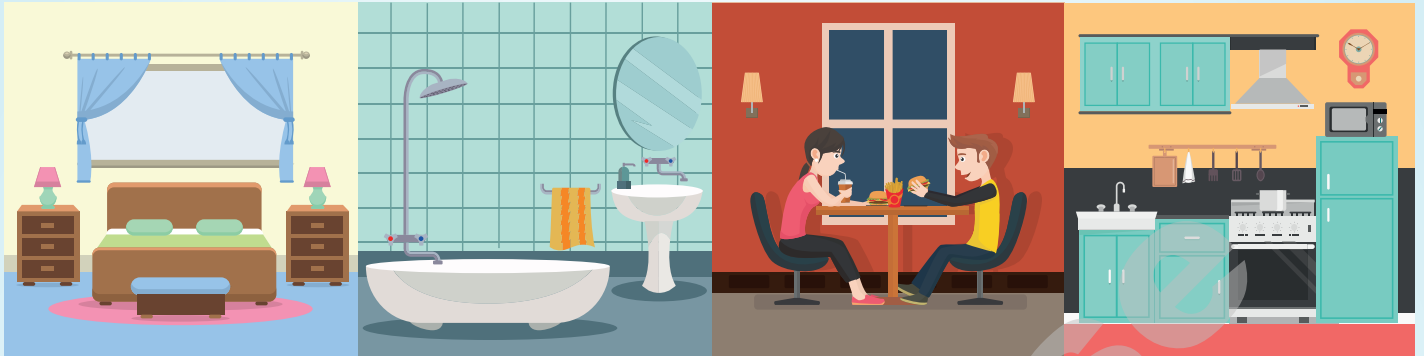

Bedroom

Bathroom

Dining room

Kitchen

Look at the pictures and unscramble the letters.



opas

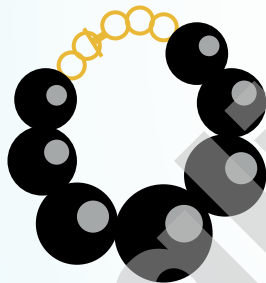

cakelenc



eonpelve



eky

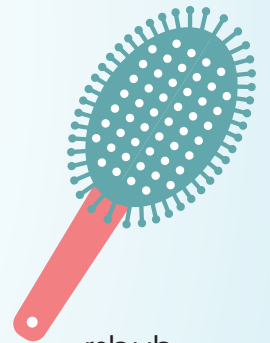

rsbuh



stropdca



ocbm



patsm

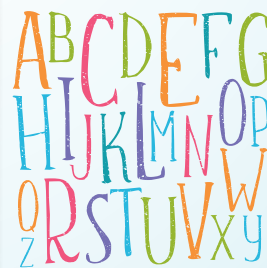

etsetlr

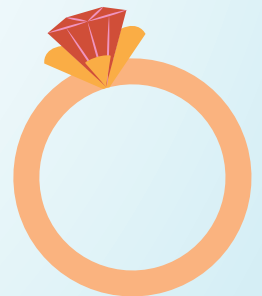

ginr

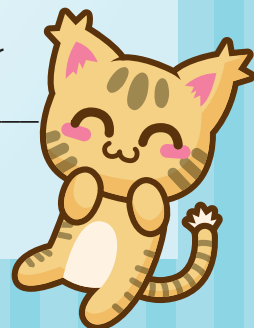

Adjectives

Read and complete. Then match the descriptions with the pictures.

tidy

untidy

quiet

full

empty

broken

noisy

1 There is nothing inside, it is _____.

2 When the music is loud, it is _____.

3 I dropped my cellphone, now it is _____.

4 There is no space to put more things in; it's _____.

5 Dirty, messy, _____.

6 There is no noise at all; it's _____.

7 It's clean; everything is in its place. It's _____.

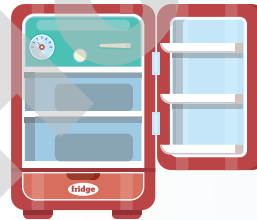
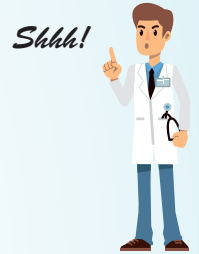

Read and complete using the adjectives from the previous activity.

1 Look! John's pencil is _____.

2 Be _____, please! Jane is sleeping.

3 My mum's bedroom is always _____.

4 I can't throw any paper in the bin because it is _____.

5 The fridge was _____ so my parents went to the supermarket.

6 John's mum is angry because his bedroom is always _____.

7 I don't like going to class 9. They are so _____.



Indefinite pronouns

Look and read. Then answer the question with a friend.
What do the words in orange mean?

Someone took my hat.



I can't find my football anywhere.



No one's got your favourite book. I am sure it is somewhere in your bedroom.

There are clothes everywhere. You won't find anything.



Use the words in pink to complete the sentences. Then write what each word refers to: people, places or things.

- 1 _____'s got my cellphone.
- 2 _____ took my calculator.
- 3 This classroom is messy. You won't find _____ in here.
- 4 I can't find my new pen _____.
- 5 _____'s got your favourite pen.
- 6 I am sure it is in your bedroom _____.
- 7 Look at this messy room. There are toys _____.
- 8 You can't find _____ in here.



Reading and writing

Read the paragraphs and complete them with the words in the boxes.

clever

difficult

everybody

popular

kind

This is my good friend Joe. (1) _____ says we are like brothers because we are always together. Joe's teacher says he is very (2) _____ because he always gets good grades in maths. I think he is quite (3) _____ among the kids at school and a very (4) _____ person to his friends and relatives. A boy like him is (5) _____ to forget.



bored

everything

noisy

tidy

lucky

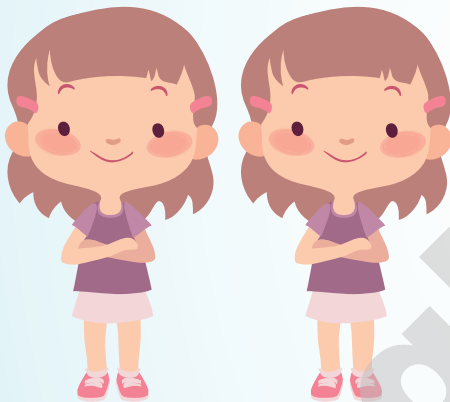

Mary and I are twins and we share the same bedroom. Mum always tells us to keep it (1) _____ and to have (2) _____ in the correct place. Today was our graduation. We were very (3) _____ to be in the same school and in the same classroom. I think we are a little (4) _____ when we are in our bedroom listening to music. We never get (5) _____.

empty

little

unhappy

broken

friendly

We are two girls and two boys. All of us take care of the baby because he is very (1) _____ and we have to be very (2) _____ with him as our parents say. Sometimes the baby cries when his bottle is (3) _____ because he wants more milk. He also cries when his toys are (4) _____. That makes him feel really (5) _____.



Vocabulary

Match the halves and write the words on the lines.

1 do me _____

2 fl mb _____

3 de mp _____

4 ha at _____

5 la or _____

6 so sk _____

7 ho ll _____

8 co ap _____



Now play with your friends.
Can you guess the words?

This is something we use to see when it is dark.

What is it?

It's a lamp!

It's a flashlight!

It's a torch!

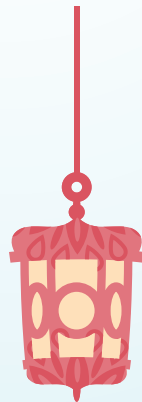

Reading

Read and complete Katy's message. Use the words on the logs. There are five words that you don't need.

Dear mum,

I'm writing this letter to tell you about our first day at school. I _____ very excited to go to school again. My friend Kim and I got off the school bus, took our _____ and walked to the entrance. I looked _____ my friend Sarah, but I couldn't find her. I even had _____ ask Miss Thompson, who _____ our English teacher, but she _____ know anything about my good friend.

Suddenly, I remembered that Sarah and her family _____ in Florida on vacation. I totally forgot.

See you at the weekend!

Love

Katy

don't

were

open

to

for

didn't

are

isn't

was

backpacks

go

is



Before or after

Look at the pictures and complete the sentences by using before or after.



- 1 Katy has breakfast _____ getting dressed.
- 2 She has breakfast _____ going to school.
- 3 She gets home _____ having a great day at school.

Now complete about you. Circle the right option.

- 1 I have breakfast **BEFORE** / **AFTER** going to school.
- 2 I have English class **BEFORE** / **AFTER** recess.
- 3 I have lunch **BEFORE** / **AFTER** getting to school.
- 4 I do my homework **BEFORE** / **AFTER** sleeping.
- 5 I play with my friends **BEFORE** / **AFTER** doing my homework.
- 6 I sleep **BEFORE** / **AFTER** having dinner.



Places in a city

Look at the pictures and draw lines.

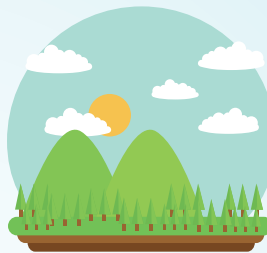
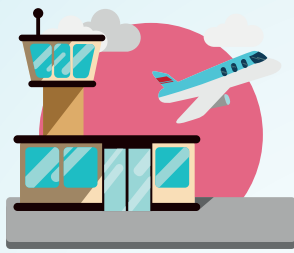

forest

train station

restaurant

university

hospital

police station

airport

museum

castle

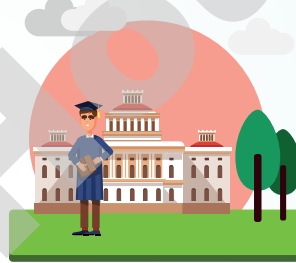

Choose four places and write descriptions.

Example

0 restaurant

This is a place where people can eat and talk.

1
.....

2
.....

3
.....

4
.....



Where

Complete the sentences with the correct words. Then number the pictures.

- 1 The police station is the place where we go to ask for help.
- 2 The forest is the place _____ we can see many trees.
- 3 The airport is the place _____ we can take flights to many places.
- 4 _____ is the place _____ we can see sculptures.
- 5 _____ is the place _____ we can study different subjects.
- 6 _____ is the place _____ we can eat delicious food.
- 7 _____ is the place _____ we can visit a king or a queen.
- 8 _____ is the place _____ we can take a train to different places.
- 9 _____ is the place _____ we can post a letter or postcard.
- 10 _____ is the place _____ we can get medicine if we are sick.

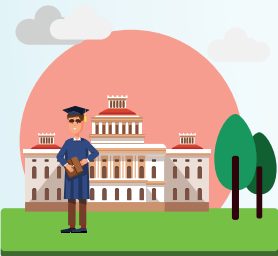

Could

Read and answer the questions.

0 Where could Kim post a letter?
She could post a letter at the post office.

1 Where could Mark buy some medicine?
.....

2 Where could my brothers study when they grow up?
.....

3 Where could Susie find a king and a queen?
.....

4 Where could Kim see nature?
.....

5 Where could my teacher take a flight to London?
.....

6 Where could my sisters take a train to Texas?
.....

7 Where could my friends eat burgers and drink soda?
.....



Where could I see famous paintings?

The kitchen

Look, read and number the things in the kitchen.

- | | | | | | | | |
|---|----------|---|--------------|----|------------|----|----------|
| 1 | a bowl | 5 | a frying pan | 9 | a knife | 13 | a fork |
| 2 | a spoon | 6 | a chair | 10 | a tray | 14 | a glass |
| 3 | a table | 7 | pepper | 11 | a cucumber | 15 | a cooker |
| 4 | a tomato | 8 | salt | 12 | an apron | 16 | an onion |



Verbs

Look, read and match.



Mum, it tastes delicious!

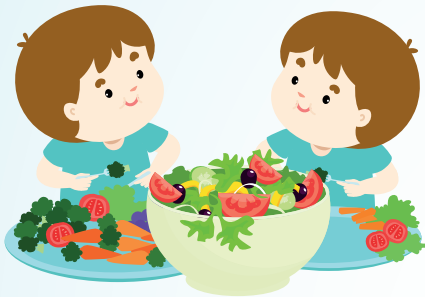

It sounds like birds singing!



It looks messy!



It smells like chicken soup!



It looks like salad!



Practice

Read and complete the sentences with the correct form of the verbs. Then number the pictures.

smell

look

feel

taste

sound

- 1 That _____ like someone playing the drums.
- 2 That _____ like grape ice cream.
- 3 Your hair _____ very soft.
- 4 It _____ delicious!
- 5 They _____ very happy.



Reading and writing

Look and read. Write yes or no.



Examples

- 0 There are two beetles on the book.
- 0 The boy is wearing a blue bracelet.
- 1 There are four orange fish in the water.
- 2 There is an eagle in the sky.
- 3 There is a small hole in the tree.
- 4 The insects are flying near the boy.
- 5 The yellow bird is in the nest.
- 6 There is a torch next to the boy.
- 7 There is a brown tent behind the big tree.

_____ yes
_____ no



Listening

Listen and draw lines.

Lucy

David

Robert

Wendy



Richard

Peter

Helen



Reading and writing

Look and read. Choose the correct words and write them below.

There is one example.

a toothbrush
a school
soap
diaries

a university
a toilet
comics
a tent

a flat
books
postcards
newspapers

a playground
a towel
chemist's

- 0 You use this to clean your teeth. a toothbrush
- 1 You use this when you want to get dry, after washing or swimming.

- 2 This is the place where young children go to study and learn.

- 3 This is a kind of home, and it's usually on one floor. _____
- 4 These usually have a picture on the front side, and you send them to your friends and family. _____
- 5 You can buy these every day, and they tell about things which are happening in the world. _____
- 6 You can use this for cleaning your body when you are having a shower.

- 7 This place is outside and it may have a lot of swings and other games for children. _____
- 8 You can buy medicine at this place. _____
- 9 You write in these to help you remember important dates and times.

- 10 These are usually for children and pictures help to understand the stories in them. _____



Listening

Listen and write. There is one example.



- 0 Has lost: _____ a schoolbag _____
- 1 Where lost: _____ in the _____
- 2 Colour: _____
- 3 Size: _____
- 4 Things inside: _____ cellphone, _____ and books
- 5 Name inside: _____ James



How does it make you feel?

Look and complete the words. Then number the pictures.

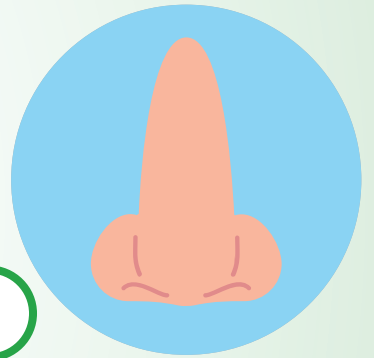
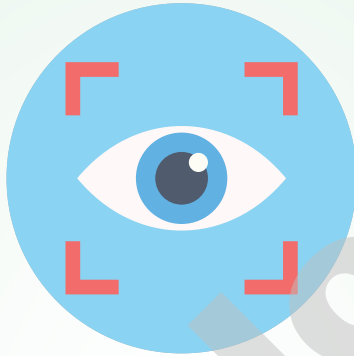

1 s _____ l

2 t _____ h

3 t _____ e

4 s _____ t

5 h _____ g

Read and write.

What things do you like ...?

smelling

touching

tasting

seeing

hearing

_____	_____	_____	_____	_____
_____	_____	_____	_____	_____
_____	_____	_____	_____	_____



How does it make them feel?

Look at the pictures and complete the sentences.

tired

scared

stomachache

sad

bored

angry



1 When Henry eats too many burgers, it makes him have a _____.



2 When the baby cries all night, it makes mum _____.



3 When my friend is alone at night and he hears a strange noise, it makes him feel _____.



4 When students copy in the exams, it makes the teacher feel really _____.



5 When I have math class, it makes me get _____.



6 When Sally can't go out to play, it makes her feel _____.



This makes me feel...

Read and write about you.

1. Insects make me feel _____ .
2. Math lessons make me feel _____ .
3. Watching the stars makes me feel _____ .
4. Going shopping makes me feel _____ .

Read and write.

reading playing a strange noise
swimming in the sea hurting myself

How do the activities in the box make you feel?



5. _____ .
6. _____ .
7. _____ .
8. _____ .
9. _____ .

When I have to solve a math problem at the board, I feel very nervous.



Pair words

Look at the pictures and write the words.



s _____



f _____



p _____



c _____



c _____



e _____



n _____



s _____



s _____

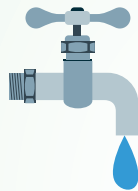

w _____



s _____



h _____



s _____



b _____



s _____

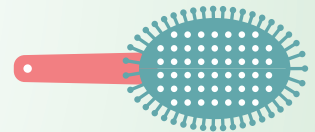

b _____

Make pairs with the words. Then write what group each pair belongs to. Look at the example.

1. shoes

socks

clothes

2.

.....

.....

3.

.....

.....

4.

.....

.....

5.

.....

.....

6.

.....

.....

7.

.....

.....

8.

.....

.....



My school

Match the words with the pictures.



arts



geography



math



history



science



music



languages



sports

Talk to a friend about the subjects above. Then interview other friends.

What is your favourite subject?

What subject is not easy for you?

How do you feel when you have an exam?

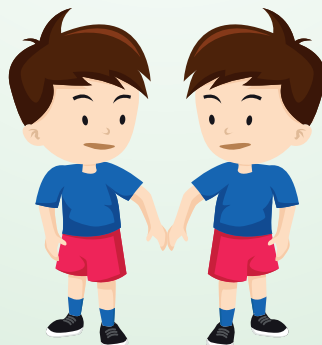

I like science because we do experiments and discover new things.

History is not easy for me because there is a lot of information.

Exams make me feel worried and nervous.



What time do you ...?

Look, draw and write the times. What time do you do these things?

get up



go to school



have lunch



do homework



watch TV



go to bed



Use the information above to write complete sentences.

From Monday to Friday ...

- | | |
|-------------|-------------|
| 1. I _____. | 4. I _____. |
| 2. I _____. | 5. I _____. |
| 3. I _____. | 6. I _____. |



What time is it?

Look at the clocks and write the correct times.

It's seven o'clock.
It's half past twelve.
It's twenty before five.

It's half past two.
It's a quarter past three.
It's a quarter to five.

It's a quarter past eight.
It's half past six.
It's half past eleven.



What is it made of?

Look at the pictures and draw lines to match them with the words.



shelf

toy duck

sweater

magazine

fork

page

scarf

necklace

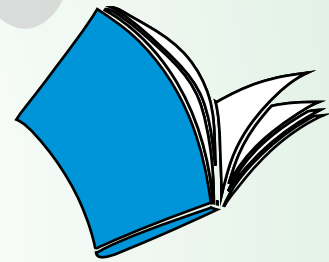
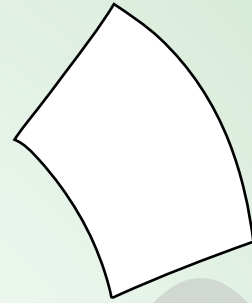

Write the words from the previous activity in the correct column. Then think of more words to complete the table.

PLASTIC

METAL

WOOD

PAPER

WOOL

_____	_____	_____	_____	_____
_____	_____	_____	_____	_____
_____	_____	_____	_____	_____
_____	_____	_____	_____	_____



Let's go out!

Read and look. Then choose a word from each column and write it on the correct line.

theatre
cinema
zoo
circus
museum

films
flags
stage
paintings
cages

artist
clowns
zookeepers
directors
actors



Name:

.....

Thing:

.....

People:

.....



Name:

.....

Thing:

.....

People:

.....



Name:

.....

Thing:

.....

People:

.....



Name:

.....

Thing:

.....

People:

.....



Name:

.....

Thing:

.....

People:

.....



When?

Look at the pictures and unscramble the letters. Then write about you.
What do you do in the / at ...?



imgnron

.....

rteafonon

.....



ngveine

.....

thgin

.....



Read and look at the words in colours. Then write about you.
Tomorrow ...

1. **Kim is going to wake up** at 6:30 in the morning.
2. **my neighbors are going to have a picnic** in the afternoon.
3. **my friends are going to play** soccer in the evening.
4. **I am going to go to bed** early at night.

Write about you and your family or friends.

1.
2.
3.
4.



Reading

Look at the pictures and read the sentences. Then complete.

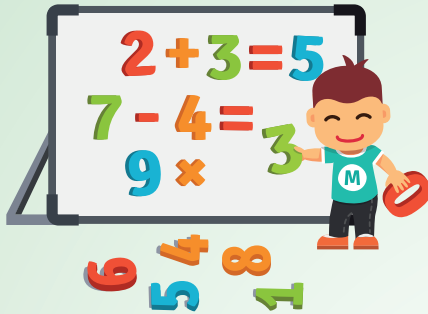

Our math class is very interesting.



We were interested at the math class.

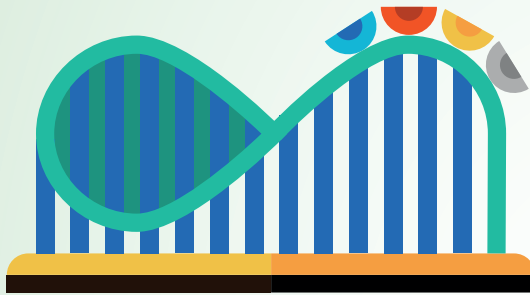

The roller coaster was very exciting.



The kids were really excited.

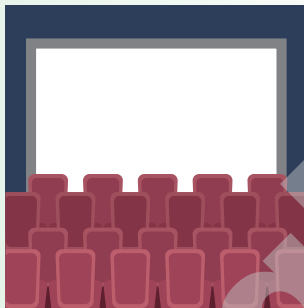

The movie was very bor_____.



The audience was very bor_____.



The music was annoy_____.



My mum was annoy_____.



Reading

Read the story. Choose a word from the box for each line. There is one example.



Last weekend my brothers and I couldn't go out to play because it (0) **rained** all day and it was very windy. My parents couldn't (1) _____ us to the shopping centre because the roads were closed. That's the reason why we had to stay at home all the weekend, but we had a lot of fun. Dad brought some DVDs and we (2) _____ them in the living room. We sat together on the biggest sofa we have there. Mum prepared some bowls of popcorn and my brothers and I prepared the drinks. Then we played some board games. After that, my dad played the guitar and we all (3) _____ together. That evening, our (4) _____ was so cold that we decided to sleep in our parents' room, but it was fun because they have a big TV in there. We brought some (5) _____, put them on the floor and watched another DVD. It was about midnight when we all fell asleep.

It rained a lot last weekend, but it was a great, great weekend.

rained	sing	drive	sang	drove
watch	living room	blankets	watched	bedroom

Now choose the best name for the story. Tick one box.

A film about rain

It was a boring weekend

A happy rainy weekend



Listening

Listen, colour, circle and draw.

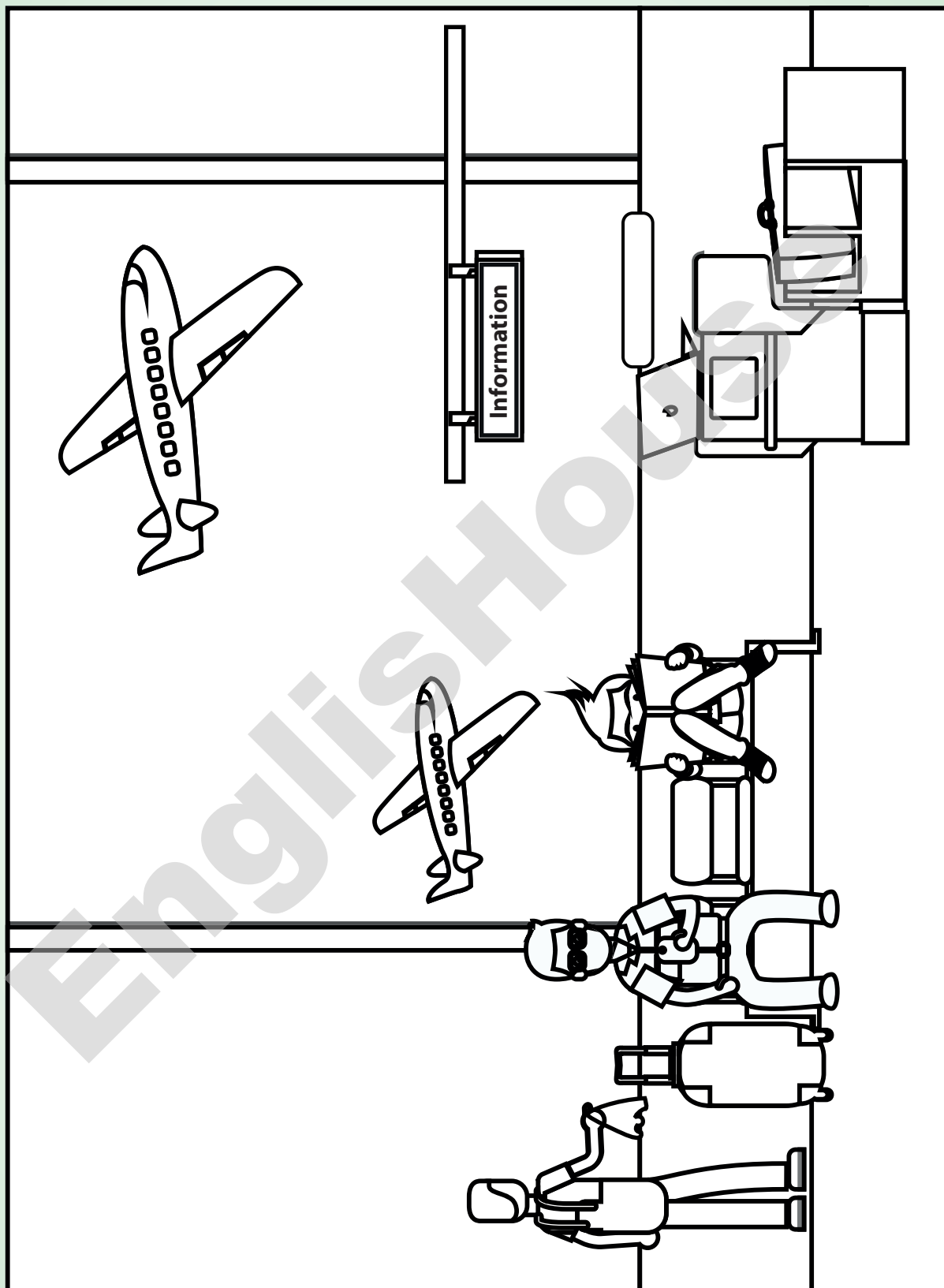

Reading

Look at the pictures and read the story. Write some words to complete the sentences about the story. You can use 1 to 4 words.



My name's Rossy. My uncle Pet is an actor. He's not a famous one, but last year he made a film with some actors who are **very famous**. It was very exciting. It was the best job he's had. In the film, he was a bad man! He had to steal a bag of money from a bank.

One day, uncle Pet was at a park working with some other actors and the camera men. He had to run across the grass with the bag of money. The camera men had to be running behind him to get the scene filmed.

A policeman was in the street. He didn't see the cameras. What he saw was my uncle Pet running with the bag. Then the policeman shouted "Stop!" He ran after my uncle and took him to the police station in his police car. The policeman asked uncle Pet lots of difficult questions about the bag of money. He couldn't believe the answers uncle Pet was giving to him. But then one of the famous actors from the film called "Fred Stars," arrived at the police station to help. When Fred explained everything, the policeman believed what uncle Pet had said.

The policeman said "Sorry!" and uncle Pet went back to work with his bag of money. Outside the police station, a journalist took a photo of uncle Pet with Fred Stars and it appeared in the city newspaper next morning. It was very funny!

Example

0 Rossy has an _____ **uncle** _____ who is an actor.

0 He made an exciting film last year with some _____ **very famous** _____ actors.

Questions

1 Pet stole some _____ in the film.

2 In the film, Pet had to run on the grass with _____.

3 There was a _____ in the street who saw him.

4 The policeman drove uncle Pet to _____.

5 Pet had to answer _____ about the money.

6 _____, who was another actor, came to the police station to help.

7 The next day, a picture of the two actors was in _____.

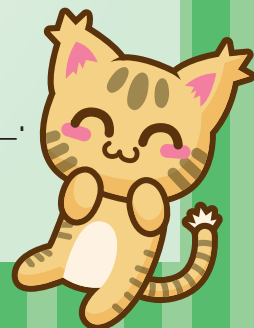

Vocabulary

Look and read. Draw lines to match the meanings with the correct words.

medicine

0 You can buy a cup of drink here.

a chemist's

a sledge

1 When it's dark, use this to see.

a torch

an ambulance

2 You study this to know about the past.

3 You can take this if you feel sick.

a circus

a station

4 You can see clowns in this place.

café

maths

5 If there's snow, use this to go downhill.

6 You go to this place to catch a train.

history

a theatre

7 You put your clothes in this when you travel.

a factory

a suitcase

8 You study this to know about rivers and lakes.

9 This vehicle can take you to the hospital.

geography

10 This shop sells things that help you feel well.

a nurse



Jobs for everyone

Look and write the words. Then tell a friend what each worker does exactly.

engineer dentist mechanic journalist footballer artist
 tennis player singer teacher painter policeman photographer



What work would you like to do?

Look and practise the conversation.

What work would you like to do?

I would like to be a teacher



I wouldn't like to be a policeman. They wear uniforms. I don't like uniforms.

Look at the pictures and complete the sentences.



I'd like to be a _____ because _____
_____.



I'd like to be a _____ because _____
_____.



I'd like to be a _____ because _____
_____.



I'd like to be a _____ because _____
_____.



I'd like to be a _____ because _____
_____.



Where do you work?

Match the pictures with the words. Then tell a friend what people can do in each place.



restaurant

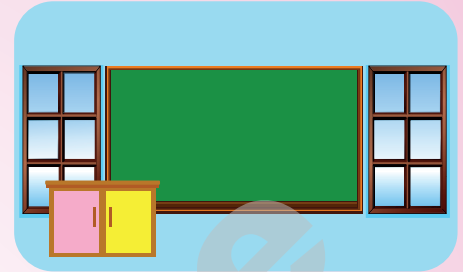

classroom



kitchen



airport



office



police station



hospital

fire station



circus



theatre

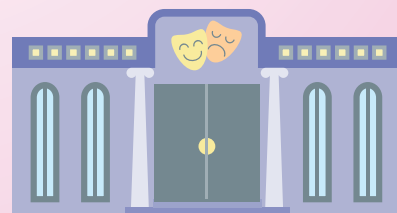

Who is it?

Read and write the jobs. Then number the pictures below.

- 1 He works in a restaurant. He asks you what you'd like to eat and he brings you the food. He is a
- 2 She works in a hospital. She helps people who are ill. She is a
- 3 He works in a circus. He wears a big, red nose. He makes you laugh. He is a
- 4 He works in a police station. He helps people who are in danger in the streets. He is a
- 5 She works in a classroom. She teaches children and helps them to learn. She is a
- 6 She works in a circus. She takes care of animals that are ill. She is a
- 7 He works in a restaurant. He works in the kitchen. He cooks delicious dishes. He is a
- 8 He works in a fire station. He puts out fires. He is a
- 9 He works in an airport. He flies airplanes that take people to different places. He is a
- 10 She works in a hospital. She helps doctors. She gives medicine to ill people. She is a
- 11 He works in an office. He checks our teeth and repairs the ones that are not ok. He is a
- 12 She works in an office. She answers the phone and uses a computer. She is a

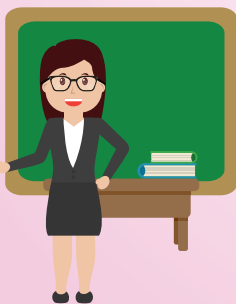

Find someone who!

Interview your friends and write.

Name:

I'd like to be a vet because



Name:

I'd like to be a doctor because

Name:

I'd like to be a driver because



Name:

I'd like to be a pilot because

Write about your dream job and share with your class.

.....

job



My homework

Help George and Nancy to complete their homework with the verbs in the boxes and the words for the pictures below.

George's homework

work

tell

write

Hi, I am George. My dream job is to be a _____. They _____ in an _____ and _____ stories for _____ or _____ them on TV.



Nancy's homework

works

travels

has

Hi, I am Nancy. I'd like to be a _____ like my mum. She _____ lots of important _____. She _____ on a _____. She also _____ to other countries.

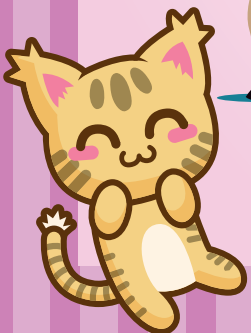

Jobs and places

Find workers (8) and the places where they work (8).

a	t	j	o	u	r	n	a	l	i	s	t	b	g
a	c	t	o	r	i	l	o	f	f	i	t	r	g
r	a	f	a	r	m	f	f	t	f	a	r	g	f
t	s	t	u	d	i	o	a	a	r	t	i	s	s
d	o	c	t	o	r	r	o	f	f	i	c	e	a
r	e	r	e	s	t	a	u	r	a	n	t	b	r
a	r	e	n	f	a	r	m	e	r	a	o	l	e
w	o	p	l	o	h	o	s	p	i	t	a	l	d
s	c	h	o	o	l	h	g	a	r	a	g	e	u
a	o	y	n	e	a	c	t	a	r	t	i	s	t
c	u	o	t	h	e	a	t	r	e	c	s	e	j
a	d	g	t	e	c	u	t	e	a	c	h	e	r
m	e	c	h	a	n	i	c	m	k	c	o	o	k

Put the workers and the places together.



- 1
- 2
- 3
- 4
- 5
- 6
- 7
- 8



I'm a king

Look and complete the words.



k _____



q _____



p _____



p _____

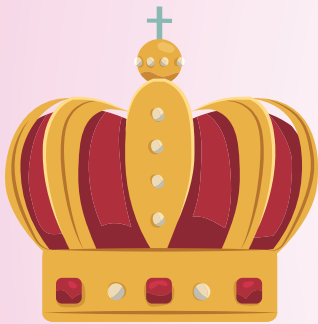

c _____



r _____



s _____



j _____



c _____



g _____



r _____

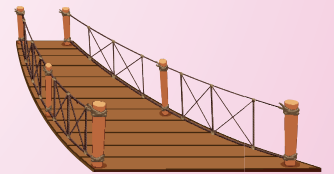

b _____



The costume party

Look and read. Complete the conversation using the words in the box. Number the bubbles to show how the conversation goes.

weekend
make

costume
queen

's
go

jewels
flowers

a
wear

king
crown

1 Are you going to to the party, Clare?

2 Yes! I can't wait more. It's going to be a great

3 No, I'm not. This time I'll be a

4 Are you going to wear your fireman

5 And what are you going to

6 Well, this year I am going to my costume!

7 That..... fantastic!

8 Yes. I will be a

9 Wow! Are you going to wear a

10 Yes. But it won't have It will have flowers!

11 That's great idea!

12 Yes. I will be the queen of the



Reading and writing

Read and complete the paragraphs using the words in the box.

made
won

ate
had

gave
asked

danced
wasn't

drank
live

was
came



Last weekend we _____ a party. It _____ Halloween, but we decided to wear costumes. All my friends _____ incredible clothes. Some were so original that we had a contest.

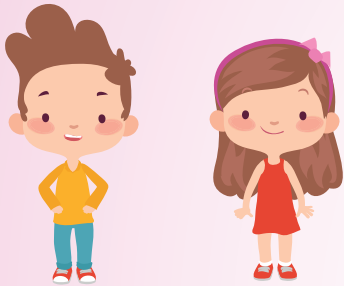

The party _____ at Charlie and Clare's house. They _____ us a very nice welcome with a big smile.



Many children _____ to the party. Daisy and Fred, who _____ in another state, _____ their parents to drive them here, It was a great surprise for us.



We _____ to fantastic music, _____ some delicious sandwiches and _____ fresh lemonade. We were very happy.



Our friend Peter _____ the contest. He wore a Frankenstein costume. It was great!

Directions

Look and answer the question. Then practise the conversation with a friend and answer the second question.

What happened?

I'm lost!
Where's the school?

But where is the north?



We have to walk to the north.

This way.

What can they do to find the school?

Look at the map and the compass. Then read and complete the sentences.



- 1 We are at the sports centre, we have to walk to the _____ to get to school.
- 2 We are at the mall, we have to walk to the _____ to get to school.
- 3 We are at the bookstore, we have to walk to the _____ to get to the sports centre.
- 4 We are at the barbershop, we have to walk to the _____ to get to the café.



A great competition

Look and read. Complete the paragraphs using the words in the box.

ran competitions race fell winner footballers
place goals volleyball golf match



Last month we had an excellent day. It was the sports day. All the children had to participate in one or more

.....
This year we learned about a sport called



My friends and I were on a football team so we participated in that sport. All the had fun. It was an exciting, my team won by three to one.



Then my brother a race and he got first It was awesome.



The first grade teacher invited her students to play They had a special net for little kids.



The last competition was a bike It was incredible until Frank off and hurt his leg.



Tags

Read and match the words with the definitions.

- | | | |
|--|------------|--|
| • This is a team game. | baseball | • You need a racket to play this. |
| • Someone who plays football is called... | score | • When a person wins a game or a competition, you say he is the... |
| • You need to know this to find out who's winning. | winner | • You need to score this more times than the others to win a game. |
| • The person who wins a game or a competition gets this. | goal | • You hit a small ball with a club in this game. |
| • People can find out who is the fastest runner in this competition. | tennis | • You use a bat and wear a big glove in this game. |
| | volleyball | |
| | footballer | |
| | prize | |
| | race | |
| | golf | |

Look and read. Write the correct question tags on the lines.



He is a very good baseball player,

.....?

isn't he?

doesn't he?

aren't he?



They will win this match,

.....?

don't they?

aren't they?

won't they?



She plays basketball very well,

.....?

doesn't she?

does she?

will she?



He can score many times in a game,

.....?

can he?

isn't he?

can't he?



Unscrambling

Look and put the words in the correct order.

1 has - Mrs Brown - school - just - at - arrived

2 made - cakes - The parents - already - snacks - have - and

3 just - The teachers - tidied - the classroom - have

4 flags - playground - put - already - in - have - The children - the

5 have - their tickets - paid - The parents - already - for

6 prizes - hasn't - The teacher - yet - the children - their - given

Match the pictures with the sentences.



Sophia has just made a sandcastle.

Betty has just scored two points.



My brother has already won the race.

Johny has already drunk a glass of water.



Jane has just helped her teddy bear.

Michael has just thrown the snowball.



Reading and writing

Read and choose a letter for each answer in the conversation.

Two friends are talking about going to the cinema.

What does the girl say to the boy?

Boy: Hello, how are you, Holly?

0 Girl: C.

Boy: Oh! What are you doing this evening?

1 Girl: _____.

Boy: What is it called?

2 Girl: _____.

Boy: What is it about?

3 Girl: _____.

Boy: It sounds exciting! Can I come too?

4 Girl: _____.

Boy: Great! Where can we meet?

5 Girl: _____.

Boy: Ok, see you there.



- A A man who gets lost in the mountains.
- B You can buy it there. It's not a problem.
- C Fine, thanks. But I've been busy.
- D How about the shop next to the cinema?
- E "White Lands" My favourite actress is in it.
- F At a quarter to six?
- G Of course you can!
- H I'm going to see a film at the cinema.



Reading and writing

Read the text and choose a word for each line.

Bookshop

Example Last year Lucy won a competition in _____ a _____ bookshop. She had
1 to guess the number _____ words in one of the books. The book
2 was _____ long, and she decided that the answer was about ninety
3 thousand words. A _____ weeks later, Lucy got a letter from the
4 bookshop. It said, "Well done!" You _____ the correct
5 number of words in our competition. _____ you like to come to
the bookshop to get a present?" Lucy felt very happy, and the next day
6 she _____ to the bookshop again. There were a lot of people
there because a famous TV actress was visiting the shop. She gave a
7 book to Lucy and said, "This is _____ you.
8 It's a book _____ the English countryside that I have just written."
9 Lucy thanked her and said, "It _____ very interesting and the
10 photos are beautiful. Please, _____ you write your name here for
me? I want to show all my friends at school. I've enjoyed today. Thank you
very much!"

Example

	<input checked="" type="radio"/> a	an	any
1	off	to	of
2	so	too	very
3	some	few	little
4	have	had	has
5	Would	Do	Will
6	goes	went	gone
7	from	for	by
8	in	of	about
9	looks	look	looking
10	could	may	might



Listening

Listen and write a letter in each box. There is one example.

Where are they going to put each thing?

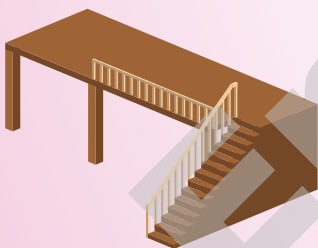
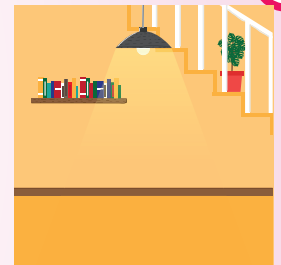
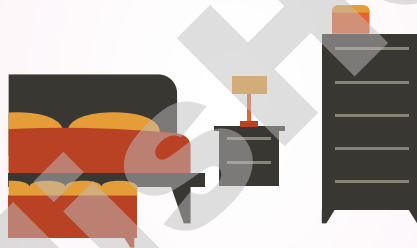
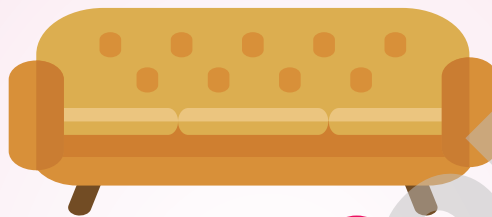
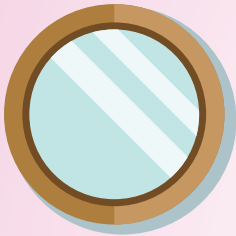
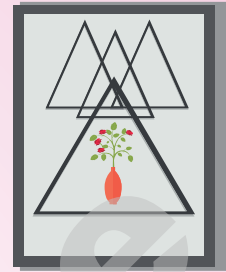
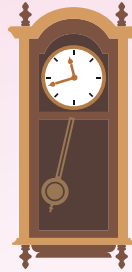

Listening

Listen and colour.

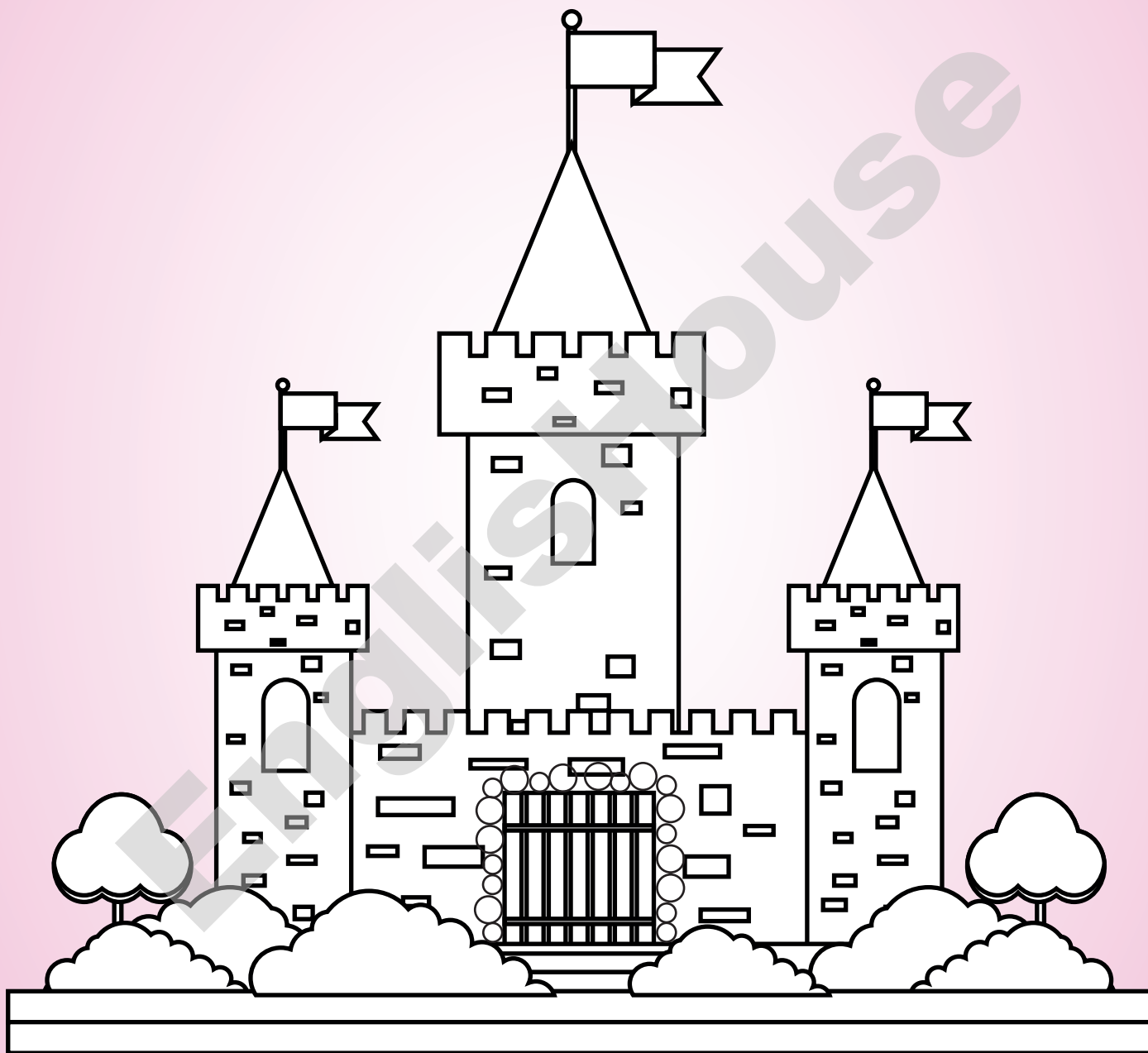

Reading and writing

Read the story and write the missing words. Write one word on each line.



Dear Sam,

It (0) _____ was _____ my birthday last Saturday and we went (1) _____ the circus with my mum and dad. First we saw the elephants and then (2) _____ was a football game with ten dogs, but I liked the clowns more (3) _____ anything else; I enjoyed a lot. The last two acts were amazing - there was a man playing with two tigers (4) _____ an elephant at the same time. I was afraid because it looked very dangerous, and at the end, eight monkeys danced some strange music; they were very funny. I (5) _____ like to go to the circus again next month!

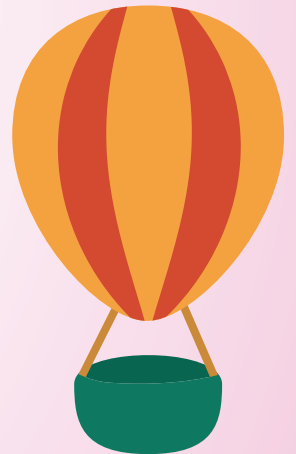
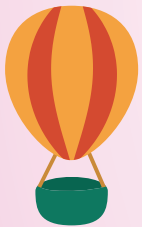

Love,
Jessie

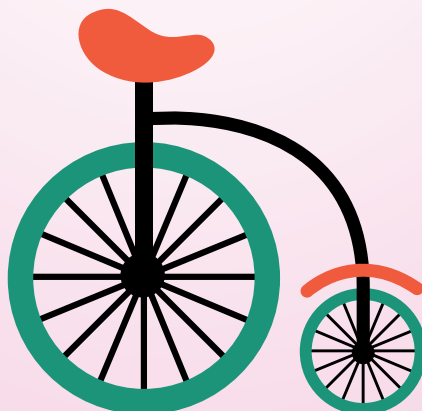

Camping

Look and read. Practise the conversation with a friend.

John, give me a marshmallow, please!

It's a quite dark night!

Here you are, George!

We can use my torch!



Read and match.

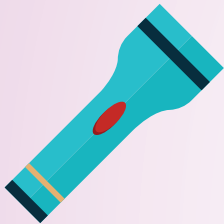

This is a small controlled fire that is used for cooking.



This is an area of land that is higher than the surrounding land.

This is a large bag used to carry things on your back.



This is a kind of small home you take with you when you go camping.



This is a small light you can hold in your hand. It gets its power from batteries.



This is a flow of fresh water that goes across the land into the sea, a lake or another river.



This is a large hole in the side of a hill.

This structure is built over a river to cross from one side to the other.



Camping items

Read and write.

I need something ...

- to light the path at night!
- to read at night!

b _____

m _____

n _____

- to carry all my things!
- to be safe outside!
- to cover myself from the rain!
- to eat!



Interview some friends and write.

What animals can we find in a cave?

What can we see at night in the campsite?

.....

.....

.....

.....

Look, read and complete the sentences.

(i g t b r h)

The stars are _____ at night.

(r a k d)

The cave was very _____, so we used a torch to see.

(e s a r t n g)

We saw a _____ bird that had three eyes.

(f o t s)

We touch a rabbit with _____ fur.

(v a e h y)

We carried a lot of things. Our rucksacks were very _____.

(o n a e l)

You mustn't walk _____ in the forest.

(i r g t h e n f d e)

Helen was _____ when she saw the bats in the cave.

(o r i h r e l b)

Sarah said that spiders were _____.

(e l a r g)

We saw some swans in the lake. They are _____ birds.



Adventure

Use the words in the box to complete the paragraph.

walking hurt whispered walked put found feeling
whistling telling reading smiled shining decided

George _____ to me "Let's have an adventure!" I _____ at him. We _____ some snacks in our pockets and _____ straight up the path by the river. The other kids were _____ stories by the fire and the grown-ups were _____ some magazines. We were _____ together through the woods. George was _____ happily, but suddenly he _____ himself with a rock. The night was dark, only the silver moon was _____ brightly in the sky. I was _____ a little frightened. We _____ a cave entrance so we _____ to go in.



Camping day

Complete the text with the sentences below.

George felt a little bit bored. The children were telling stories (0) _____ **near the camp fire** _____ . He whispered to me "Let's have an adventure!"

He went to his tent and put several snacks in his pockets. I put some clothes in a rucksack, but George said that it was very heavy and we couldn't take it.

(2) _____ when we left the tent so we didn't need to use our torches.

We walked past the lake and through the bridge and then straight on up the path by the river. (3) _____ by the fire so they didn't see us.

We had a wonderful view of the hills. (4) _____ , but I asked him to stop because it was very noisy.

(5) _____ when George fell over. He hurt himself with a rock, but he was very brave and didn't cry.

It was very late in the evening when we arrived at the entrance of a cave. We shouted "Hello!" but no one was there. (6) _____ , but we decided to go in.



a) near the camp fire.



b) We were walking through the woods

c) George was singing happily



d) I was feeling a little frightened

e) The grown-ups were resting in the tent



f) The moon was shining brightly

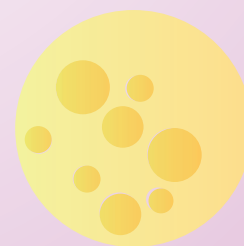

Hidden words

Write the word for each picture. Then write the first letter of each word on the line on the right to find the hidden words.

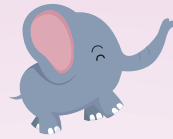

Use the hidden words from the previous activity to complete the paragraph.

Last weekend we went camping. We packed our clothes in rucksacks. I forgot to carry a _____ which is very important when you go camping because you need it in the nights. In the woods, nights are _____ so you may need to make some _____ to find the camp; you can also use the fire to stay warm and cook.

My brother likes biscuits very much so he put some in his _____ to eat them during the day.

One morning we went for a walk and we found a large _____ where lots of bats lived.

I didn't know why my rucksack was so _____ when we were going back home. Then I unpacked and I found some rocks my brother had put in it.



The camping report

Complete the text with the verbs in the box.

were walking was raining were looking was shouting lived
was crying ran were eating calling were looking

George and I went into the cave. I was very frightened because I don't like insects. George's leg was hurt so he needed to rest a bit before going back. We sat on the ground and suddenly we saw some eyes. They _____ at us. Lots of bats _____ in that cave. We _____ inside their house. I _____ loudly. I thought the bats would bite me so I _____ to get out of that place. George _____ "Holly, I can't run! Please wait for me!" But I couldn't stay there. I ran until I was at the entrance of the cave. It _____ and George finally reached me - we stayed together. We remembered that there were some biscuits and chocolates in George's pocket. We _____ them when we heard some voices _____ our names. Our parents _____ for us in the stormy night.



Favourite activities

Look and write verbs.



_____ up hills



_____ snowballs



_____ tennis



_____ on a boat trip



_____ new clothes



_____ leaves



_____ vegetables



_____ at the beach



_____ a snowman



_____ on sledges



_____ down



_____ down hill



_____ kites



_____ in the woods



_____ in the garden



The perfect time

Put the activities in the previous activity under the best season to do them.

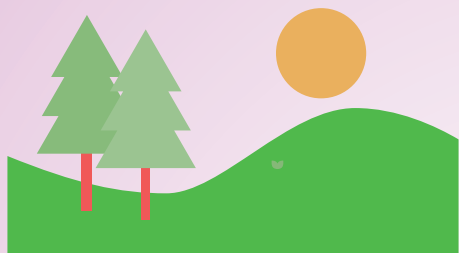

In spring

.....
.....
.....
.....
.....



In summer

.....
.....
.....
.....
.....



In autumn

.....
.....
.....
.....
.....



In winter

.....
.....
.....
.....
.....

Look and read. Then talk to a friend about your favourite activities and when you like doing them.

I like swimming in the sea during the summer.



I prefer to have dancing lessons in the spring.



Information charts

Look, read and write a letter in each box.

It's windy. It's cloudy. It's rainy.
 It's sunny. It's snowy. It's stormy.



Read and write.

In spring it's always _____ . In autumn it's always _____ .
 In spring it's never _____ . In autumn it's never _____ .
 In summer it's always _____ . In winter it's always _____ .
 In summer it's never _____ . In winter it's never _____ .

Write about your favourite season.

Months

.....

Weather

.....

Clothes

.....

Favourite season

Activities

.....



Reading

Read the conversation and choose the best answer to each question.

What does Harry say to Michael?

Michael: When are you going back to school, Harry?

0 Harry: _____ F _____

Michael: Did you enjoy your summer holidays?

1 Harry: _____

Michael: Where did you go?

2 Harry: _____

Michael: Have you done all your homework?

3 Harry: _____

Michael: Who's going to be your next English teacher?

4 Harry: _____

Michael: Oh, my sister was in her class last year!

5 Harry: _____

A Not everything, but I still have time.

B I met them in the classroom.

C Yes, we had a great time.

D Yes, she told me she is a great teacher.

E You can't do that.

F In two weeks, Michael.

G Miss Wallace.

H We went to the beach.
We stayed in a big hotel.

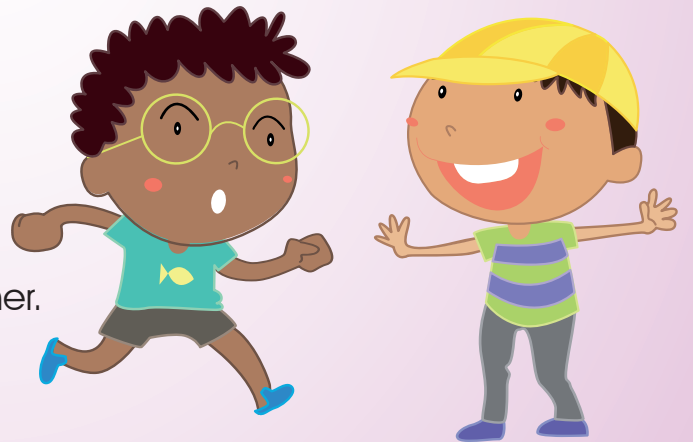

Listening

Listen and write a letter in each box.



Maria

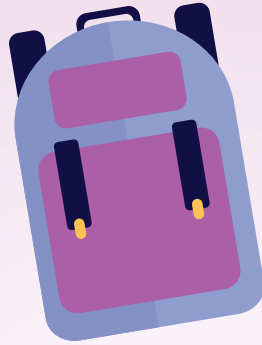

A



B



Paty



Betty



C

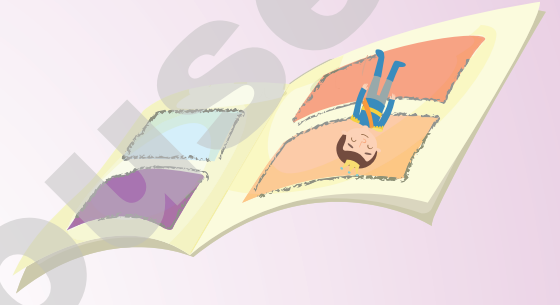

D



Brandon

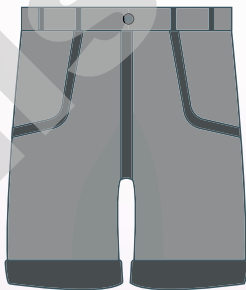

E

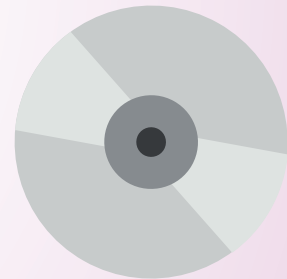

F



Bryan

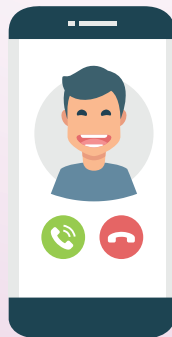

G



H



Johny



Reading

Read the text. Choose the right words and write them on the lines.



- 0 My friend Helen _____ has _____ two pets; a dog and a cat. She is
1 _____ to get a new one. It will be a strange pet. It will be a baby bat.
2 She says that the first time she saw bats on a video she liked _____ a
3 lot. Her mum says it may be a _____ difficult to have a bat as a pet
4 because they sleep during the day and fly, eat and play _____ night.
5 Helen says she can _____ a house for it and have it in the garden.
6 This way the bat could look _____ its food. Bats like eating insects and
7 the garden is a perfect place to find them. She read in _____ book that
8 bats can drink milk so she wants _____ new pet to drink some of the milk
9 she likes. The only thing Helen is worried about is that bats _____ see;
they can only hear.
10 She knows her new pet _____ know her face, but she says she will sing a
lot to it.

Example

	have	has	having
1	planning	plan	plans
2	them	their	them
3	few	little	lot
4	at	in	on
5	make	making	makes
6	of	at	for
7	the	with	a
8	she	her	hers
9	do	can	can't
10	won't	will	can



Listening

Listen and tick (✓) the box. There is one example.

0 What time did the boy leave home?

7:00



7:45



7:30



1 What should the boy put on the desks?



2 Which is the boy's desk?

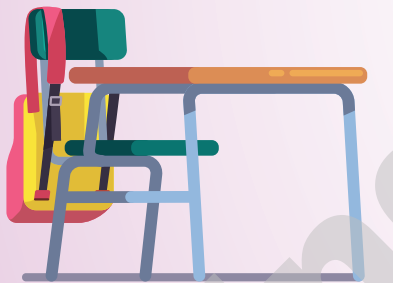

3 What subjects will the boy study this morning?

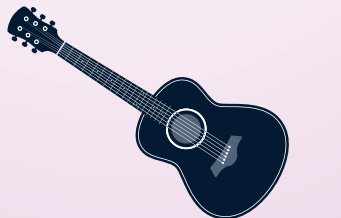
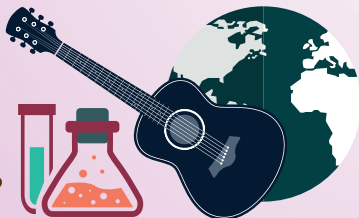

Reading and writing

Read the story and write the missing words. Write one word on each line.



Example Katy's grandfather lives on a farm in the country, a long way from the nearest town. He has cows, sheep and a horse; and a very big vegetable garden. Katy loves visiting him. She goes there every Saturday.

- 1 In the mornings she helps her grandfather to _____ cheese from the sheep's milk. In the afternoon she rides the horse.
- 2 Katy _____ back home in the evenings, but sometimes grandfather's old car does not start quickly. When it happens, Katy stays on
- 3 the farm and goes back home _____ Sunday morning. She usually
- 4 _____ the 9:00 am bus, but last Sunday the bus didn't come and
- 5 she had _____ ride the horse all the way back home.



Holidays

Look and read.

I'm ready for the holidays!
Look, my suitcase is full!

Should I take my sunglasses too?



You should take your sneakers!

Yes, you might need them too!

Look at the pictures and the letters. Write the words.

e l t b

l e g v o s

a z m a i g e n

p o s a

o s c k s

i g h t s t

u n s g l s e s a s

a e k r s n s e

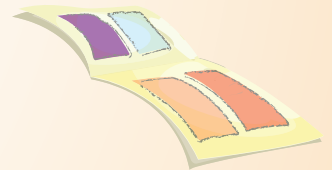
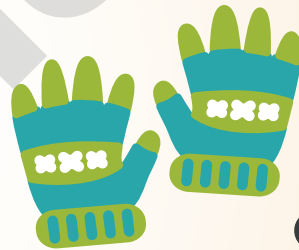

Might – Should

Read and match the halves.

- | | |
|--|--|
| 1 You should take soap for the holidays. | • and toothpaste. |
| 2 You should take your toothbrush | • and enjoy the trip. |
| 3 You should take a camera | • Look for someone to take care of it. |
| 4 You shouldn't take your pet. | • It doesn't matter where you are going. |
| 5 You should smile | • for the great moments. |

Read and write what you should take on each holiday trip.

A skiing holiday
I should take ...

A camping holiday
I should take ...

A beach holiday
I should take ...

_____	_____	_____
_____	_____	_____
_____	_____	_____

Read and complete the sentences with adjectives.

- | | |
|--|---------------------------|
| 1 You might need a cap. It's a _____ day. | (u n y n s) |
| 2 The suitcase is _____ . We're ready to go. | (l u l f) |
| 3 You might need an _____ book. | (n i g t r e s e t n i) |
| 4 You might need your _____ T-shirt. | (t r p i e d s) |
| 5 We might need a _____ umbrella at the beach. | (e r g l a) |
| 6 You might need your _____ sunglasses. | (w n e) |
| 7 You might need a _____ sweater. | (m a r w) |



Speaking

Look at the pictures and tell the story to a friend.



Read the questions and match them with the answers.

Where is Emma today?

Have you ever traveled by plane?

Emma is going to see the pyramids. Have you ever seen them?

Have you ever ridden a camel?

No, I haven't. We always travel by train.

No, I haven't.

Yes, but not in Egypt. I was at the zoo!

She is in Egypt!



Present perfect

Look and write the verbs in the past participle form.

REGULAR	
climb	
play	
stay	
burn	
travel	
visit	

IRREGULAR	
see	
ride	
eat	
win	
fly	
go	

Look and write verbs in the past participle form to complete the questions.

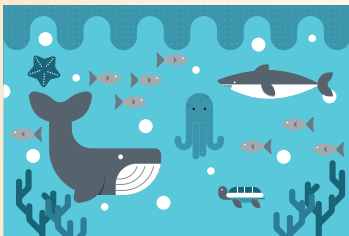

- | | | | |
|---|---------------------|--------------------|-------------------------------|
| 1 | Have you ever _____ | a shark? | Yes, I have. / No, I haven't. |
| 2 | Have you ever _____ | a kite? | Yes, I have. / No, I haven't. |
| 3 | Have you ever _____ | baseball? | Yes, I have. / No, I haven't. |
| 4 | Have you ever _____ | with dolphins? | Yes, I have. / No, I haven't. |
| 5 | Have you ever _____ | a snowman? | Yes, I have. / No, I haven't. |
| 6 | Have you ever _____ | a race? | Yes, I have. / No, I haven't. |
| 7 | Have you ever _____ | chopsticks to eat? | Yes, I have. / No, I haven't. |
| 8 | Have you ever _____ | a sandcastle? | Yes, I have. / No, I haven't. |

Answer about you – choose an answer for each question and tell the class about the experience.



Practice

Read and underline the sentences in the present perfect.

Holly is telling her mum what has just happened to George and Harry.

"Mum, Harry is ill." said Holly. "Oh, dear!" replied mum. "Yes, mum." said Holly.

"What has happened?" asked mum. "Well, we had lunch in a really nice restaurant and the waiter brought lots of food; meat, salad, fruit and some cakes.

Harry loves cakes. That's why he ate five slices." said Holly. "Five!" shouted mum.

"And now he says that his stomach hurts!" said Holly. "Of course his stomach hurts!"

said mum. "Where is he now?" asked mum. "He's laying down in bed. The doctor gave him some medicine; he said that he had to go without food for 24 hours. He is not happy about that." said Holly.

And what about George? What happened to him? asked mum. "Oh, mum. George hurt himself. We went for a camel ride at the zoo. George was riding his camel too fast when he fell off." said Holly. "Oh, no! Is he ok now? Can he walk?" asked mum.

"Well, the doctor has seen him and says he has broken his toe. He can't walk very well. He is watching cartoons now."

Look and unscramble.

1 camels. / The / ridden / children / have

2 too. / cakes / Harry / many / has / eaten

3 doctor / The / given / some / has / Harry / medicine.

4 has / himself / George / too. / hurt

5 broken / has / toe. / George / his



A letter to grandma

Read and complete the letter using the words in the box. Follow the colour pattern.

steps

bus

cakes

restaurant

desert

pool

were

was

went

stayed

brought

met

took

arrived

ate

was crying

was looking

was riding

was feeling

Dear grandma,

This _____ the best day of my holiday. We _____ in a very large hotel near the sea in Egypt. My mum decided to lie near the hotel _____. Dad _____ for adventure. Early in the morning, we _____ a bus and started our journey into the _____. We _____ at the pyramids at midday. It was not very hot and sunny; the air was very warm. We _____ on a tour inside the great pyramid. We had to climb lots of high _____ in the dark. It was very exciting!

Near the pyramids, we _____ a friendly man who had some camels. So we went on with a camel ride. Harry _____ his camel too fast, and suddenly, he fell off! The man tried to help Harry because he _____ pain in his foot. Harry _____ so dad had to carry him back to the _____. We _____ very hungry. We _____ in an Egyptian _____. The waiter was very kind, he _____ us delicious _____. Harry ate five slices of cake so he felt ill all the way back to the hotel.



Geography

Look, read and match the places with the objects.



sand



rocket



waterfall

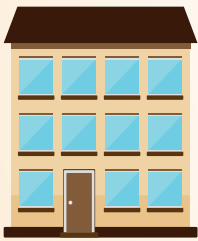

building

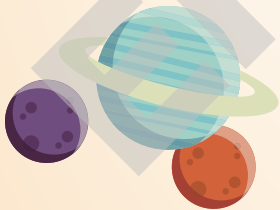

planets



sun

space



rainbow

sky



shell

beach



trees

city

mountains



clouds

forest



stars

desert

jungle



lights



Read the conversation and complete the answers the kids could give.

The teacher told us interesting information about dinosaurs, didn't she?

Yes, she did. She said that _____

Then she said that _____

She also said that _____



Read and number the sentences to answer the question.

- Why did dinosaurs become extinct?
- a) The light from the sun couldn't get to our planet.
- b) Plants didn't grow anymore.
- c) A large rock from another planet hit our world.
- d) That's why dinosaurs became extinct.
- e) Dinosaurs had nothing to eat.
- f) The environment changed suddenly; the sky was full of grey clouds.

1



London

Look and write vowels to discover what the boy said about London.



T_d_y th_ t__ch_r t_lk_d
_b__t th_ h_st_ry _f
L_nd_n. 'v_ l__rn_d th_t
L_nd_n w_s _ q__t_
sm_ll c_ty _n th_ 14th
c_nt_ry.

Read and match the information with the pictures.

1 People first bought newspapers in London.



2 People enjoyed watching actors on the stage at London's first theatre.



3 People were frightened because of London's biggest fire ever. It was called "The great fire of London".



4 There were walls around the city to make it safe. It looked like a very large castle.



5 People saw firemen and fire engines in the streets of London for the first time.



6 Croydon is a large town in south London, England.



Reading and writing

Read and complete the paragraphs with the verbs in the box.

was preparing
were decorating

was coming
were sharing

were waiting
was putting



Yesterday was my birthday and was also Christmas day. I was happy because of my birthday, but I was sad because none of my friends could come to my house. They _____ the night with their families because it was Christmas. Every year I have this strange feeling, "Happy and sad".

My mum _____ dinner. My sister and I helped her. I love Christmas dinner because there are always delicious dishes that we can only eat on this special day. This makes my birthday very special too.



In the afternoon, my sister and I _____ the Christmas tree while my father _____ lots of lights on the house roof. Our house is always full of Christmas lights.

All my family was together. We _____ for the Christmas dinner. My mum cooked for more than two hours. We had turkey, spaghetti, mashed potatoes and lots of delicious desserts. The best part was when mum brought my birthday cake and when I had a wish!



My family gave me some presents like new clothes, a soccer ball and some videogames. Later we went to bed because Father Christmas _____ . He always brings special presents for all the kids on this special day.



England

Read and complete with the words in the boxes.

about is Now a

ago in what to

_____ we are learning
_____ the 19th century.
Remember, _____
century _____ one
hundred years.



We're finding out _____
it was like _____ live
_____ England two
hundred years _____.

Read and complete the paragraph using the verbs.

used to go didn't have didn't get was had worked didn't need

Life _____ not the same for all the children during the 19th century. Children from working class families _____ toys. They _____ enough money to buy food, so children _____ long hours to help their parents, but children from rich families _____ toys, they _____ on holidays and _____ to work.

Look up information about school in the 19th century. Write in the box and glue a picture to illustrate.

School in the 19th century

.....
.....
.....
.....
.....

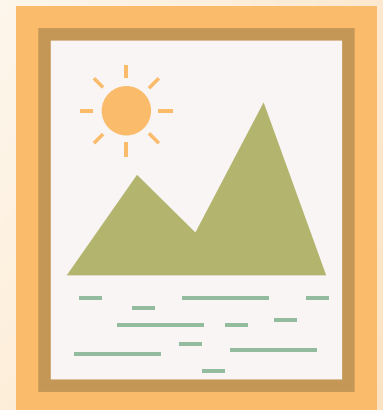

The past

Look and read.

We've read about life in the 19th century. One interesting thing we found is clothes.

This is an example of how they used to dress.

Do you like their clothes?



Use the information in the boxes to write complete sentences.

People

couldn't

speak
keep
fly
go
watch
take
wear
light

to other countries by plane.
their food cold in a fridge.
a film on a big screen.
to other planets in a rocket.
to anyone on a cellphone.
photographs.
their houses with electric lamps.
sneakers.

- 1
- 2
- 3
- 4
- 5



The future

Look and read.

I hope we'll visit other planets.

Perhaps we'll fly in rockets through space.



We might live on different planets.

We might meet aliens and learn their languages.

Read and write names below the pictures. Look at the example.



Sarah will go into space and walk on faraway planets.



Katy will be a famous singer in London.



Harry will write books for kids.



Emma will take care of animals in a zoo.

Sarah

Henry will rescue people from fires.



Robert will grow fruit and vegetables.



Holly will be a very famous painter.



Lucy will help doctors in a big hospital.



Reading

Read the story and choose a word from the box for each line. There is one example.

Frank loves working in the garden. It's his favourite hobby. He grows fruit and (0) vegetables there. Every year he enters a competition in the (1) _____ where he lives. This year they will be looking for the (2) _____ orange. He always tries to win, but all the children that participate in the competition always get big fruits. Frank is very excited and happy because he thinks he can (3) _____. The piece of orange he grew for this year's competition is really big. It looks like a football. He can't hold it with one hand; he has to use both (4) _____. He read in a book that he had to give his fruits water and some vitamins. He got surprised when he learned about all the things he had to do to grow his fruit and vegetables; and now he knows that taking care of the things he likes is an (5) _____ of love.

vegetables
biggest

hands
participate

fruit
house

smallest
act

village
win

6 Now choose the best name for the story. Tick one box.



- A secret competition
- Children like oranges
- A huge orange



Listening

Listen and write. There is one example.

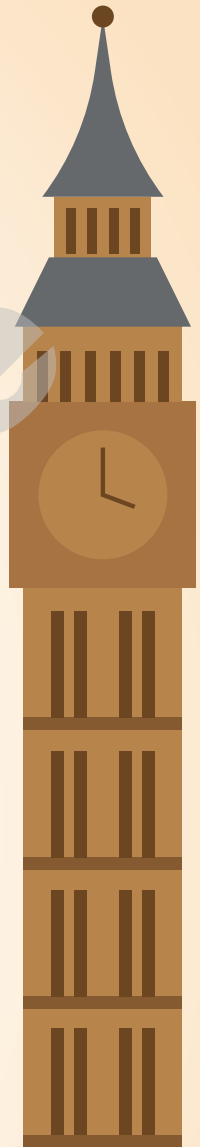

Holiday in England

0 Monday: Leave at 9:30 a. m.



1 Tuesday: Visit _____

2 Wednesday: Take a _____



3 Thursday: Go to _____

4 Friday: Play _____

5 Saturday: Buy _____

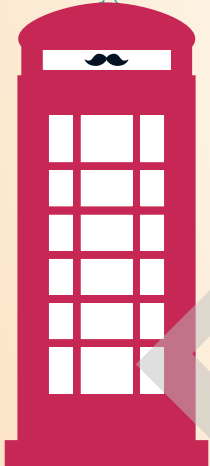

Reading

Read the text. Choose the right words and write them on the lines.

0 Last weekend Betty went camping on a hill. Before she _____ left _____, her
1 sister helped her to put _____ her camping items in her rucksack.
2 Then her mum _____ to help her too. Betty's mum asked her, "What
clothes are you taking with you?" "Two sweaters, my pink shorts, two T-shirts and
my white sneakers," she answered.

Betty's mum knew it was ok because she would be in the campsite
3 _____ two days. But she was worried about other things.
4 " _____ are you going to sleep?" "What are you going to eat?"
5 she asked Betty. Betty explained to her mum _____ she had a
complete plan, "Mum, my friend Lucy is taking a big tent, Robert is taking some
snacks and some bottles of water and juice and I am taking the salad and
6 the sandwiches you _____ for me; I'll share them with my friends."
"Ok, just don't forget to take a torch and your cellphone; call me if you need
7 _____!" Betty's mum said.

Then it was time to go, Betty said goodbye and quickly got
8 _____ the bus, but she knew she would miss her mum, and a few
9 hours _____, she decided to call her. Her mum answered the phone
and when she heard Betty's voice, she said: "Are you ok?" and it was the time
10 when Betty's mum heard the _____ beautiful words a mum can
hear:

"Mum, thank you for letting me go on this camping trip, you are the best! I love
you and I promise I will behave well – and have a lot of fun of course!"



0	leave	leaves	left
1	all	the	everything
2	come	go	came
3	for	of	in
4	When	What	Where
5	what	that	which
6	make	makes	made
7	something	someone	nothing
8	in	on	by
9	after	later	past
10	more	best	most



Listening

Listen and tick (✓) the box. There is one example.

0 What time does the café open?

9:00 8:45 9:15

A

B

C

1 What must the boy do first?



A

B

C

2 What will the boy make for lunch?

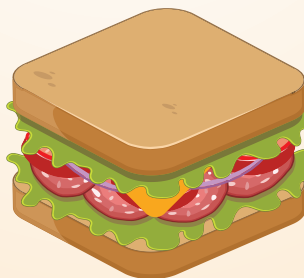
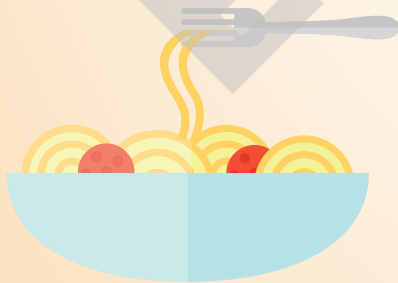

A

B

C



3 Where should the boy go to buy the eggs?



A

B

C

4 What should the boy put on the tables now?

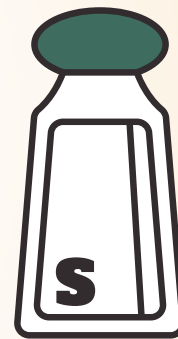
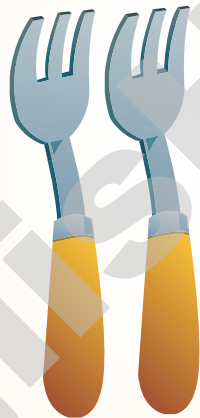

A

B

C

5 What was the weather like yesterday?



A

B

C

